

Manual del receptor DC2009

para automatismos tubulares

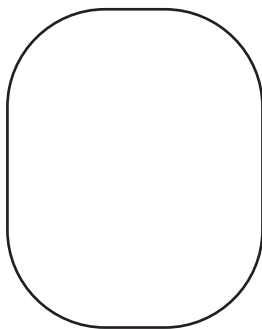

DESCRIPCIÓN DEL CONTROL



Luz roja: Encendido

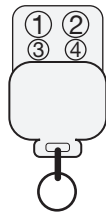
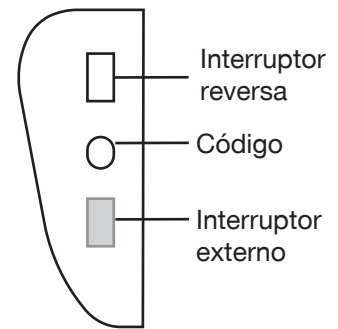
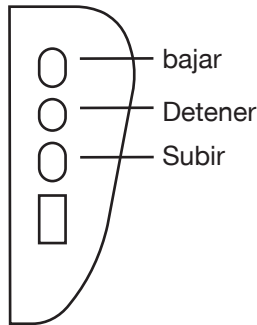

Nota: "1"= Subir "2"= bajar "3"= Detener "4" = Bloquear / desbloquear
 Mantener presionado 1 (subir) y 3 (Detener) asi como también el mando de configuración, al mismo tiempo.

FUNCIONAMIENTO

